

# MAN 51/60 Gas Variants

The catalyst for power engineering



Engineering the Future – since 1758.

**MAN Diesel & Turbo**



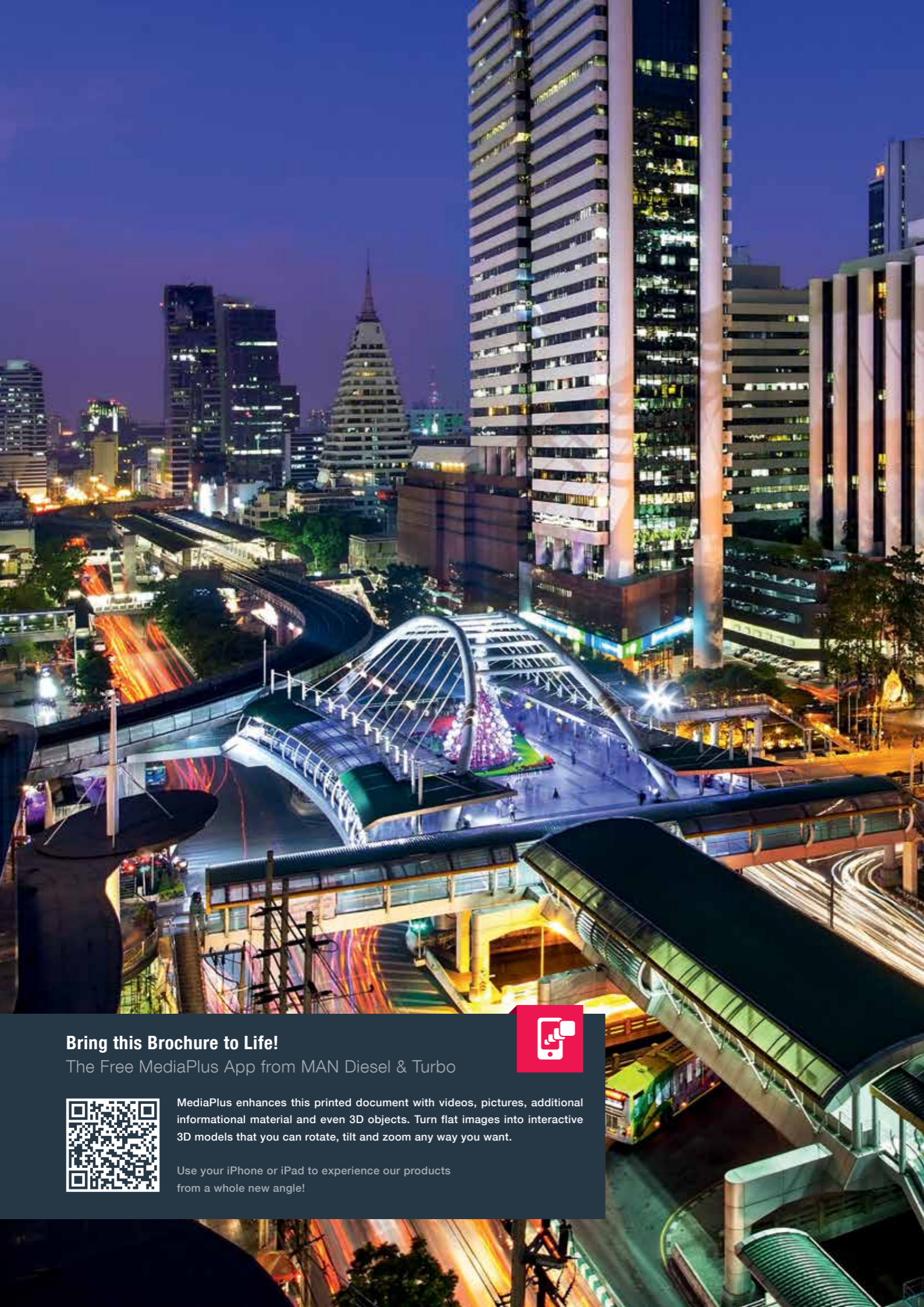

## MAN Diesel & Turbo

Powering the world – responsibly

MAN Diesel & Turbo is the world's leading provider of large-bore diesel engines and turbomachinery. Our product portfolio includes two-stroke and four-stroke engines for marine and stationary applications, turbochargers and propellers, as well as gas and steam turbines, compressors and chemical reactors.

MAN solutions can be found in ship propulsion, engine-based power plants and turbomachinery trains for the oil & gas and process industries. We support our global customers with a comprehensive range of after-sales services under the MAN PrimeServ brand.

MAN Diesel & Turbo has always been committed to increasing fuel efficiency and reducing emissions. Today, this commitment ensures that our customers are able to meet increasingly strict emissions regulations and plays a vital role in reducing the environmental impact of global trade and industry.

### Bring this Brochure to Life!

The Free MediaPlus App from MAN Diesel & Turbo



MediaPlus enhances this printed document with videos, pictures, additional informational material and even 3D objects. Turn flat images into interactive 3D models that you can rotate, tilt and zoom any way you want.

Use your iPhone or iPad to experience our products from a whole new angle!

# MAN 51/60 Gas Variants. The Power Catalysts

The next generation of large bore gas engines

# MAN 51/60 Gas Variants. Playing by the Rules

Technology with a game plan for ecological operation

Gas engines are dominating the market for electrical power generation. Much of this demand is fueled by their clean combustion, comparatively low emissions and the attractive price of natural gas. In light of their many benefits, it's really no wonder why customers trust in these highly efficient workhorses.

## Clever and clean

With the MAN 51/60G, MAN Diesel & Turbo is introducing a powerhouse of fuel economy, reliability and ease of maintenance. Not only does it give best-in-class power density compared to other engines of its kind, but it also offers clean, reliable combustion, excellent load response and stable ratings, even at high temperatures and high altitudes.

## Modern design for modern applications

As the largest and most powerful gas engine on the market, the MAN 51/60G opens doors to all-new applications. This state-of-the-art model brings the many benefits of gas engines to power stations as well as combined heat and power (CHP) and combined cooling, heat and power (CCHP) plants. It does this by using the thermal energy that has been recovered from heating and cooling processes. For full versatility, the exhaust heat can also be used to produce steam to drive a steam turbine generator.

## Engine configuration

The MAN 51/60G is available in two engine configurations:

- **Optimized for power generation**  
This configuration is specifically optimized in respect to engine efficiency without concessions to the use of waste heat.
- **Optimized for combined cycle (CC)**  
This configuration ensures an optimal balance between engine efficiency and high exhaust gas temperature for utilization.
- **Optimized for combined heat and power (CHP)**  
This configuration is designed to meet the overall thermal demand and can be used for a wide range of applications – whether at industrial or city-wide levels.

Market leadership entails more than just producing good products. Keeping up with important regulatory developments is a key success factor for pioneers in any industry. MAN Diesel & Turbo welcomes this challenge, creating technology designed to push the limits.

## Taking initiative

Reducing emissions effectively reduces the impact on the environment. To this end, we are committed to continually enhancing our technological solutions and this is reflected in the design of the MAN 51/60G. It not only achieves NO<sub>x</sub> emissions that comply with Germany's air pollution control regulations (TA Luft), but also generously undercuts the limits currently prescribed by the World Bank's clean air initiative (CAI).

## A new level of design

The MAN 51/60G is an evolution in cutting-edge technology. Based on tried-and-tested elements from the MAN 48/60 diesel engine platform, it translates first-class engineering into highly efficient performance. The engine's expert design includes a flushed pre-combustion chamber that ensures fast and reliable combustion of lean air/gas mixtures, simultaneously minimizing emissions.

## Working principle of a gas engine with spark ignition

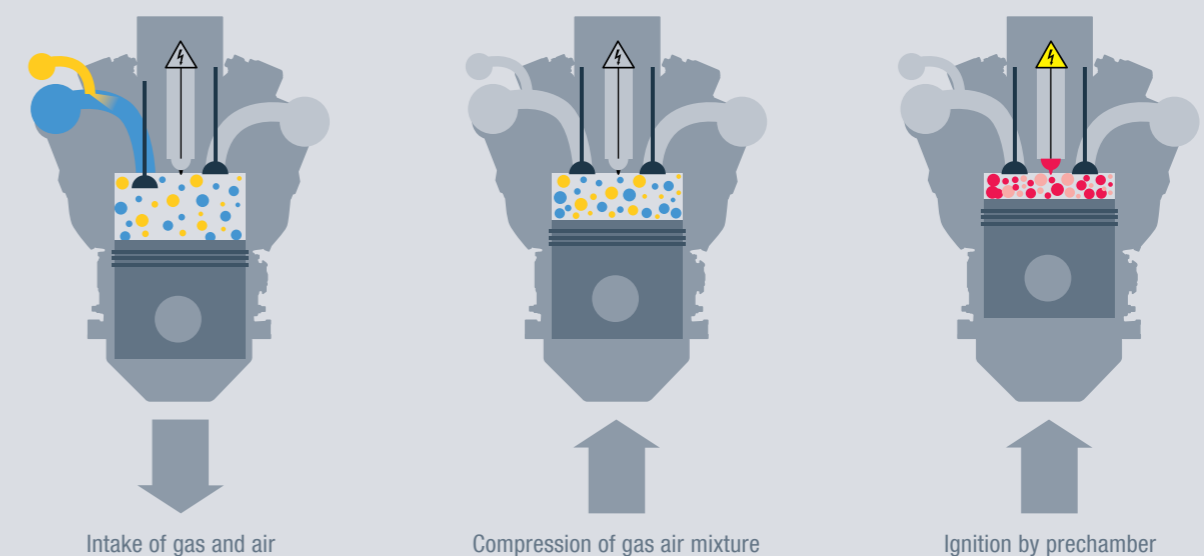

# MAN 51/60 Gas Variants. A Powerful Solution

Benefits at a glance

- Modern & innovative
- Largest & most powerful gas engine on the market
- Highest power density
- Low emissions
- Spark ignited gas engine
- MAN proven robustness
- Service-friendly design
- High & stable ratings in hot & high locations
- Ease of maintenance



# MAN 51/60 Gas Variants. High-Tech Power

Highest quality for highest output

By bringing together the best minds in the industry, MAN Diesel & Turbo has developed an extraordinary pool of genuine in-house expertise. The combined skills of this workforce flow into our renowned technologies for highly durable products, delivering on our promise of reliable operation for years to come.

## Everything working together

The MAN 51/60G can meet the most demanding customer requirements thanks to the perfect interplay between highly advanced components. The engine features SaCoS<sub>one</sub>, our top-of-the-line safety and control system which individually regulates cylinders. Armored, water-cooled valve seats keep valve temperatures low, while single-stage engine cooling and dual-stage charge-air cooling contribute to efficient and reliable engine operation. In addition, a strong, rigid engine frame spells long-term durability for the entire life of the engine.

## Dependable design

With a cylinder liner that was conceived to resist external deformation, the MAN 51/60G guarantees optimal running of the pistons. The design of the cylinder head and combustion chamber also ensure an outstanding air-fuel ratio for ideal combustion of lean air/gas mixtures. The pistons can be exchanged without removing the connecting rod and bearing cap – just one reflection of this engine's service-friendly design, which includes quick release fasteners, clamps and plug connectors, not to mention generously sized access covers to allow for hydraulic tools.

## Take your time

Excellent load response allows the engine to continue to operate economically and ecologically over time. This is further enhanced by only using high-grade materials to minimize wear, right down to the smallest detail like the ceramic coating selected for the piston rings. Overall, the rich combination of design features allows the MAN 51/60G to deliver ultimate performance along with easy maintenance, guaranteeing the longest possible time between overhauls (TBOs).

## Two-stage turbocharging option

The idea behind two-stage turbocharging is simple: two turbochargers upstream from the engine – a low-pressure and a high-pressure turbocharger arranged in series – boost the charger air pressure substantially and enable an outstanding efficiency increase. Lower fuel consumption and reduced exhaust emissions are the beneficial outcomes of this smart setup, in which the intercooler set between the two turbocharger stages is the main success factor.

With its additional power potential, two-stage turbocharging increases the power density of an engine and thus allows more compact plant designs. By adding other benefits like faster starts, stops, and ramp-ups, it improves the operational flexibility of each power plant – and this is crucial in times of fluctuating energy supplies from renewable sources and regulated energy markets.

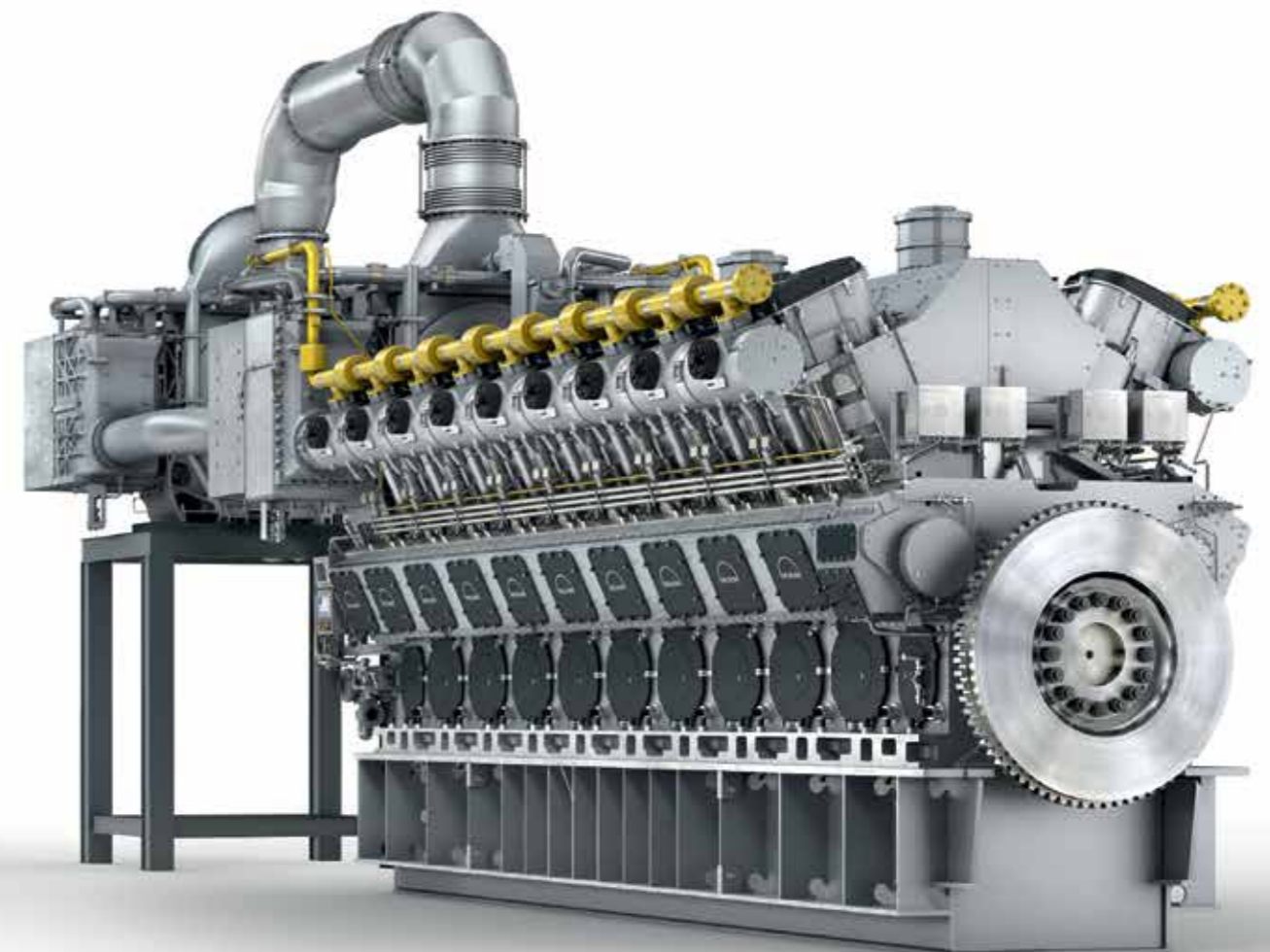

# Built around Your Needs

The MAN Diesel & Turbo gas engine portfolio



MAN V35/44G

MAN V35/44G TS

MAN V51/60G

MAN V51/60G TS

MAN Diesel & Turbo offers the most comprehensive choice of gas engines available in the market. The portfolio ranges from 7 to 20.7 Megawatts and covers the full operational spectrum – including engine combined cycle solutions. No matter which challenge faced in energy generation, MAN Diesel & Turbo has the perfect engine and power solution to tackle it. Even for gas engine-operated power plants with power outputs of up to 250 Megawatts for grid connected power or captive power applications, we are ideally positioned to serve the demand. Energy wherever you need it.

### MAN Diesel & Turbo gas engines

#### Engine type

MAN 18V51/60G TS	18,900* - 20,700*
MAN 18V51/60G	18,900* - 20,700*
MAN 14V51/60G	14,700*
MAN 20V35/44G TS	11,800 / 12,400
MAN 20V35/44G	10,200 / 10,600
MAN 12V35/44G TS	7,080 / 7,440

Output in kW<sub>m</sub>    6,000    8,000    10,000    12,000    14,000    16,000    18,000    20,000    22,000    24,000

Scheme: kW<sub>m</sub> at 60Hz / kW<sub>m</sub> at 50Hz    \* kW<sub>m</sub> at 60Hz = kW<sub>m</sub> at 50Hz  
 Example: 7,080kW<sub>m</sub> at 60Hz / 7,440kW<sub>m</sub> at 50Hz



## Technical Data

### Definitions



*Cross section  
MAN 18V51/60G*

#### **Cooling**

Cylinder cooling: Fresh water  
Charge air cooler (two-stage): Fresh water

#### **Starting method**

Compressed air

#### **Reference conditions according ISO 3046-1: 2002**

The stated consumption figures refer to:

- Ambient air pressure: 1,000 mbar
- Relative humidity: 30%
- Ambient air temperature: +25°C (77°F)
- Charge air temperature: According to engine type, corresponding to 25°C cooling water temperature before charge air cooler

# Technical Data

## Output, dimensions and weight

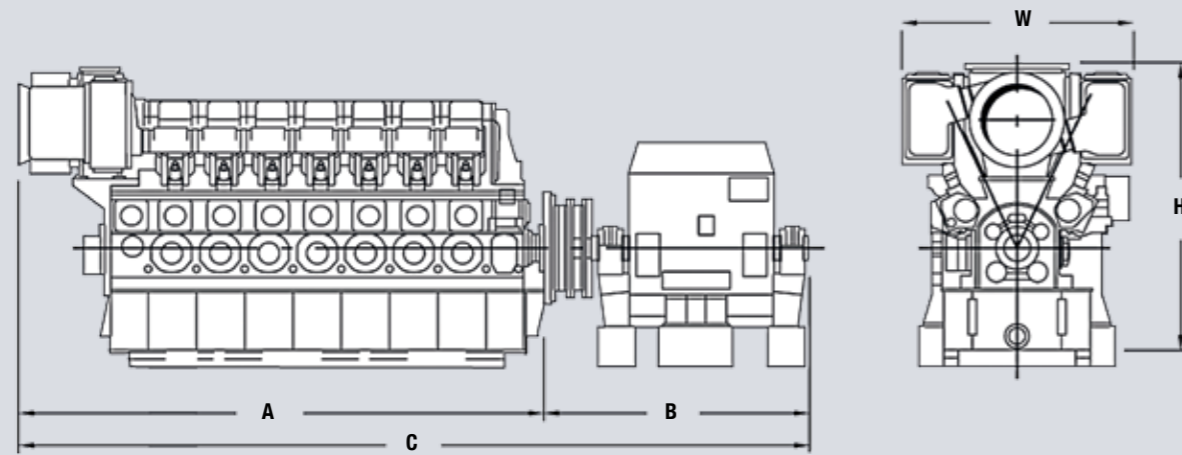

### MAN 51/60G GenSet

	A	B	C	W	H	GenSet
Number of cylinders	(mm)	(mm)	(mm)	(mm)	(mm)	dry mass (t)
18V	13,148	5,410	18,558	4,700	6,530	373

The dimensions and weights are given for guidance only.

### MAN 51/60G GenSet output (kW<sub>e</sub>)

Bore 510 mm, stroke 600 mm		18V
Engine speed	rpm	500 / 514
Frequency	Hz	50 / 60
Electrical GenSet power	kW <sub>e</sub>	18,465

### Electr. GenSet heat rate at 100% load and efficiency

Optimized for power generation (TA Luft)	7,370 kJ/kWh <sub>e</sub>
Electrical Efficiency	48.8%
Optimized for combined cycle (TA Luft)	7,561 kJ/kWh <sub>e</sub>
Electrical Efficiency	47.6%

Nominal generator efficiency: 97.7%, Methane no. ≥ 80; without pumps; 5% tolerance

Lube oil consumption	kg/h	6.7
----------------------	------	-----

Specific lube oil consumption 0.35 g/kWh, tolerance: +20%



# Technical Data

## Output, dimensions and weight

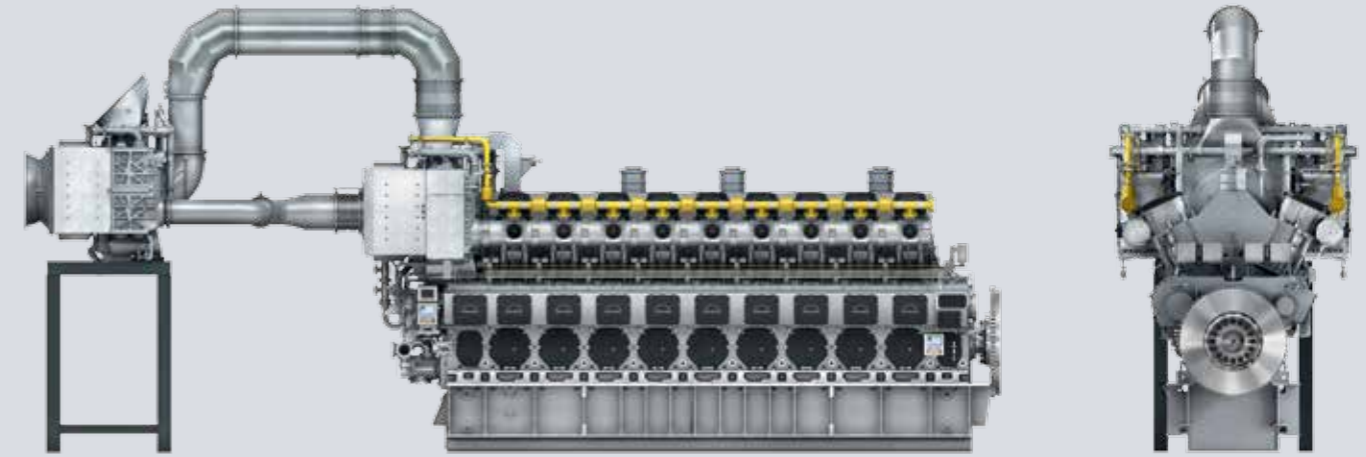
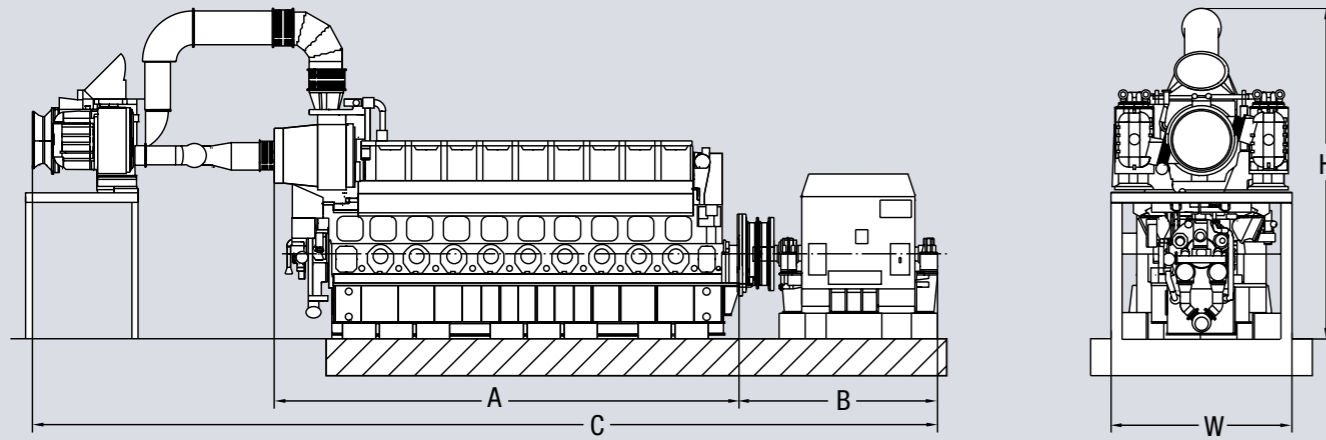

### MAN 51/60G TS GenSet

	A	B	C	W	H	GenSet
Number of cylinders	(mm)	(mm)	(mm)	(mm)	(mm)	dry mass (t)
18V	13,148	5,410	24,510	9,023	4,700	407

The dimensions and weights are given for guidance only.

### MAN 51/60G TS GenSet output (kW<sub>e</sub>)

Bore 510 mm, stroke 600 mm		18V	
Operational setup		1	2
Engine speed	rpm	500/514	500/514
Frequency	Hz	50/60	50/60
Electrical GenSet power	kW <sub>e</sub>	18,465	20,220

### Electr. GenSet heat rate at 100% load and efficiency

Optimized for power generation (TA Luft)	7,262 kJ/kWh <sub>e</sub>	—
Electrical Efficiency	49.6%	—
Optimized for power generation (TA Luft)	—	7,374 kJ/kWh <sub>e</sub>
Electrical Efficiency	—	48.8%
Optimized for combined heat and power (TA Luft)	—	7,473 kJ/kWh <sub>e</sub>
Electrical Efficiency	—	48.2%

Nominal generator efficiency: 97.7%, Methane no. ≥ 80; without pumps; 5% tolerance

Lube oil consumption	kg/h	6.6	7.2
----------------------	------	-----	-----

Specific lube oil consumption 0.35 g/kWh, tolerance: +20%

## World-Class Service

Marine propulsion, gensets, and stationary plants



### The PrimeServ offering

The MAN Diesel & Turbo Group offers worldwide, round-the-clock service, 365 days a year. In addition to MAN Diesel & Turbo's service headquarters in Augsburg, Copenhagen, Frederikshavn, Saint-Nazaire, Hamburg and Stockport, service centers on all continents provide comprehensive and continuous support.

MAN Diesel & Turbo engines are renowned for their quality and durability. We are a global organization with a strong local presence, delivering exceptional field service management, tailor-made solutions, and first-class technical support.

PrimeServ provides advice and assistance to customers throughout the product life cycle, from delivery to resale. With our far-reaching network of service centers, we respond rapidly to customer needs. Furthermore, we offer outstanding service and unrivalled technical expertise. Plus, we only use genuine spare parts – safeguarding the longevity of your engine.

### PrimeServ's aim is to provide:

- Prompt delivery of high-demand OEM spare parts within 24 hours
- Fast, reliable and competent customer support
- Individually tailored O&M contracts
- Ongoing training and qualification of operators and maintenance staff
- Global service, 24 hours a day, 365 days a year
- Diagnosis and troubleshooting with our high-performance Online Service



All data provided in this document is non-binding. This data serves informational purposes only and is not guaranteed in any way. Depending on the subsequent specific individual projects, the relevant data may be subject to changes and will be assessed and determined individually for each project. This will depend on the particular characteristics of each individual project, especially specific site and operational conditions. Copyright © MAN Diesel & Turbo. D2366418EN-N4 Printed in Germany GGKMS-05153

### **MAN Diesel & Turbo**

86224 Augsburg, Germany

Phone +49 821 322-3897

Fax +49 821 322-1460

[powerplant@mandieselturbo.com](mailto:powerplant@mandieselturbo.com)

[powerplants.man.eu](http://powerplants.man.eu)